



Racor Filter Division Europe

Commercial Marine Filtration Products

aerospace
climate control
electromechanical
filtration
fluid & gas handling
hydraulics
pneumatics
process control
sealing & shielding



ENGINEERING YOUR SUCCESS.

Never leave harbour w

The World's Best Filtration Starts



Whatever the type of commercial marine craft – from small workboat to offshore supply ship to ocean going tanker, Parker Racor is the name to trust for filtration solutions.

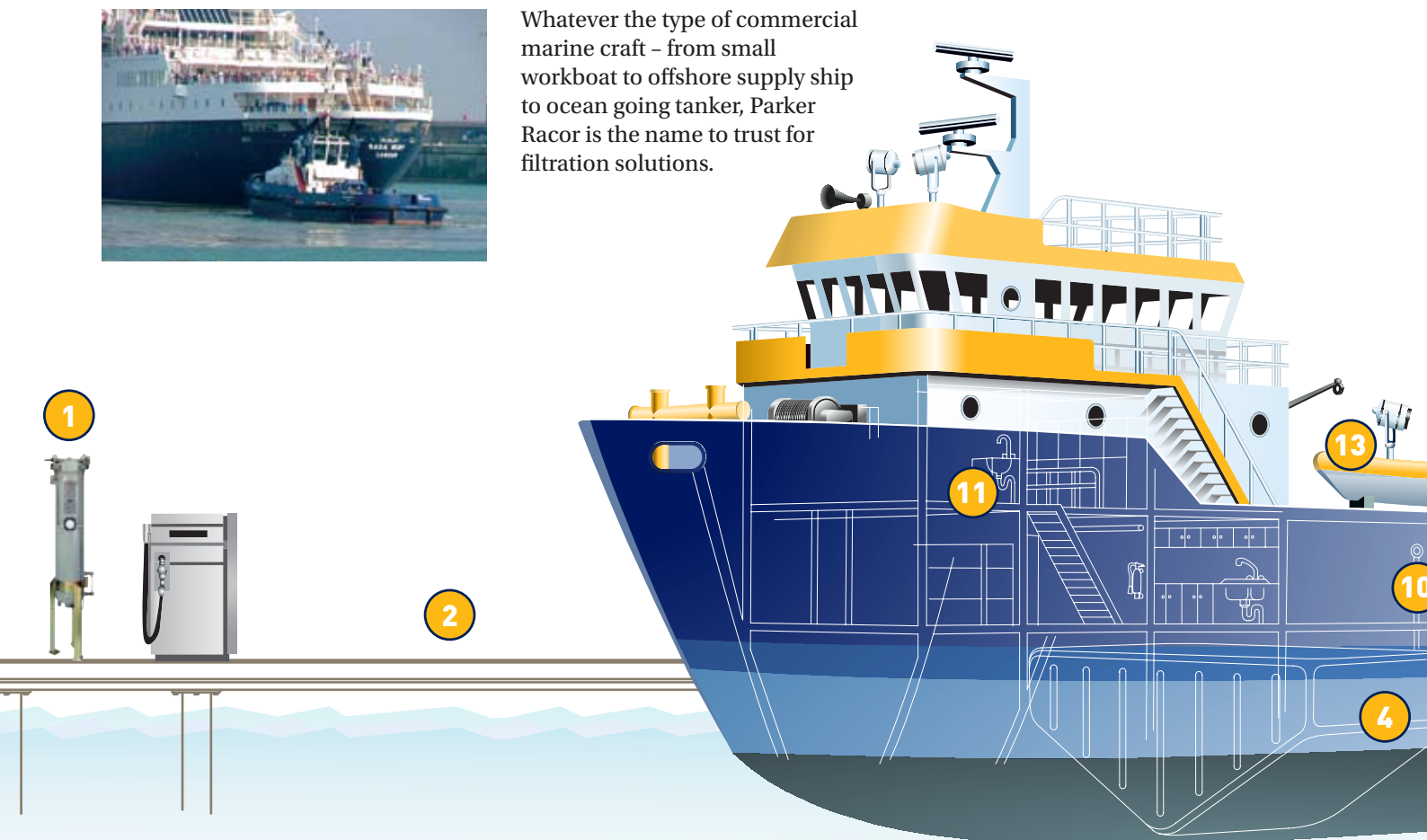

1



2



1

Fuel Delivery



2

FBO Filtration Trolley



3

DFBO & FBO



4

Marine Hose & Fittings



9

Crankcase Filtration



10

Fuel/Air Separators



11

RO Watermakers



12

Hydraulic Filters

without the right crew

with the World's Best Engineering

Racor offers a complete range of filtration products that are as efficient as they are reliable.

And for every product you see here, there are dozens of complementary models with capacity and features suited precisely for your systems and working conditions.

Cast off... but not before you've outfitted with Parker Racor – the name to trust for filtration solutions.

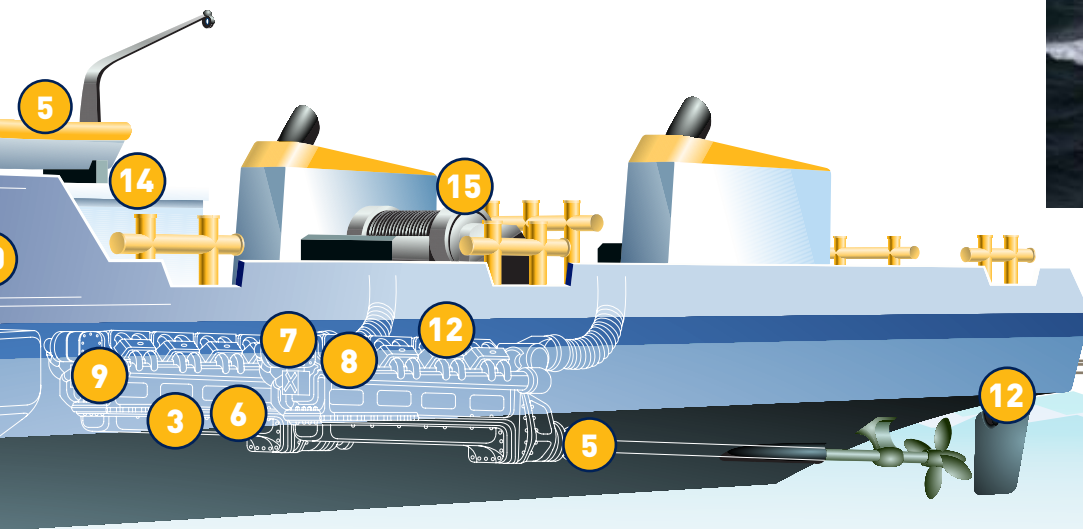

5

Filter Funnel



6

Diesel Fuel Filter/
Water Separators



7

Air Filter/
Silencers



8

ParTrap Fuel 200
Automatic Filter



13

In-Line
Gasoline Filters



14

Bilgewater Membrane
Separator



15

Parker
icountLCM20

Racor product overview

Commercial Marine Filtration Products

1 Fuel Delivery

RV Series vessels are designed for use in bulk fuel storage, fuel dispensing, fuel transfer, or large engine applications. Set up as a filter/water separator (RVFS), it removes emulsified free water and solids from diesel fuel, gasoline, and other hydrocarbon streams. Water can be drained and removed from the RVFS sump. RV Series set up as a particulate filter (RVMF) will remove solid contaminants such as dirt, rust, scale, and other solid materials from a hydrocarbon fuel stream, down to two micron.

2 Racor FBO Filter Trolley

The Racor FBO Filter Trolley is a new lightweight mobile unit ideal for on-site cleaning of fuel tanks, drums and bowsers. It incorporates state-of-the-art Racor fuel filter technology which removes potentially damaging contamination from your diesel fuel. Available with a range of filters from 1 to 25 micron it removes particles and virtually 100% water quickly and efficiently (flow rate of over 50 litres per minute).

3 DFBO Series

The new DFBO duplex filter brings Racor FBO filters to the engine room environment. The duplex design ensures that fuel is efficiently filtered all the time. The cast iron head and steel bowls mean that it can be used in Marine applications.

The DFBO comes with two bowl lengths allowing diesel flows up to 90 l/min. Depending on the elements inside the unit can be used as a prefilter, a water separator/particle filter or a water absorptive filter. Easy service, no special tools are required.

High Flow Fuel Filtration

FBO filter assemblies are designed to meet the toughest hydrocarbon refueling conditions and feature easy cartridge element change-outs. The FBO can be used on mobile refuelers or installed in refueling cabinets. It can also be used for diesel or gasoline fuel dispensing pumps, as a primary fuel filter/water separator for large diesel engines, or as bulk fuel handling, fuel transfer, and on other higher flow applications.

4 Marine Hose and Fittings

Parker Marine Hose is a USCG-rated hose for gasoline, diesel, lube oil, and hydraulic systems for commercial and recreational applications. It is fire-resistant and meets SAE J1527 Type A class 1 and SAE J1942 standards. As you'd expect, it delivers test-proven performance in a wide operating temperature range and constant working pressure. Features include long-lasting reinforced construction, kink and cut resistant, and it is compatible with a variety of standard 100R5 fittings.

5 Filter Funnel

The Racor fuel filter funnel is a heavy-duty, fast-flow, filter in a funnel that separates damaging free water and contaminants from gasoline, diesel, heating oil, and kerosene. The RFF fuel filter funnel ensures only clean fuel flows to your engine. The Racor fuel filter funnel is Teflon® coated and contains a 100 Micron Stainless Steel Filter.

6 Diesel Fuel Filter/Water Separators

When engines demand heavy-duty, high-capacity water separation and fuel filtration, the Turbine Series is the most complete, efficient, and reliable engine protection you can install. Symbolising Racor's continuing commitment to the science of filtration, the Turbine Series has established its position as the filter/separator often imitated, but never equaled. Models that include an aluminum bowl or stainless steel shield meet ASTM F51201 certification, are UL listed, American Bureau of Shipping, Veritas, Det Norske Veritas, ISO 10088, and USCG accepted. For severe service, all-metal bowls should be specified.

7 Air Filter/Silencer

Racor Marine Air Filter/Silencers remove contaminants introduced into the air from both outside and inside the vessel. Sand, salt, carpet fibers, and other contaminants are trapped in the oil-impregnated filter media. Turbo noise is reduced by the unique design of the air filter/silencer housing. An integral hose connection on the housing routes the clean blow-by from the Closed Crankcase Ventilation (CCV) filter back into the engine.

8

Par-Trap Fuel 200 Automatic Filter

Par-Trap Fuel 200 Automatic Filter Patented ParTrap Lubrication filter systems will bring automatic filter technology to lube systems. ParTrap Fuel 200 not only reduces the amount of fuel oil waste but also increases the efficiency of filtration and back flushing.

9

Crankcase Filtration

In a robust, compact package, the patented Racor CCV (Closed Crankcase Ventilation) filter provides superior oil coalescence and crankcase pressure control under the most severe conditions. The only routine maintenance required for the CCV is filter replacement. Typical service life of the high-performance filter in diesel applications is 750 hours. Some variations in service life occur depending on load profile, engine wear condition, flow, aerosol mass concentration of crankcase emissions, and soot concentration.

10

Fuel/Air Separators

Next time you fill up, watch your fuel vent line. A typical refueling will send up to one-half gallon of fuel spilling overboard. Fuel spillage is not only expensive, it's absolutely deadly to fragile lakes, rivers, and waterways. Also, USCG and other regulations prohibit the discharge of oils and violators could face civil and criminal penalties. Installed in the fuel tank vent line, the Racor Fuel/Air Separator efficiently separates air from fuel forced into the line. Air is vented, and fuel is returned to the tank. The Fuel/Air Separator captures fuel normally discharged due to agitation and thermal expansion (up to 2.4 PSI).

11

RO watermakers

Parker Racor VMT reverse osmosis watermakers are the ideal solution for where potable water is required on a reliable basis. Typical installations are Ocean Tugs, Expedition/Research vessels, Commercial Fishboats, Superyachts and Oil and Gas platforms. Each RO system includes a media prefilter, fresh water flushing system and an automatic product diversion valve to ensure only good quality water is sent to the storage tank.

12

Hydraulic Filters

Racor Water-Absorbing Hydraulic Filters feature a specially designed media that traps not only solid contaminants like dirt and rust, but damaging water as well. Water absorbing spin-on hydraulic filters are available for virtually any application and are available in a ten micron nominal rating. Racor Resin-Impregnated Hydraulic Filters include media that traps solid contaminants like dirt and rust as it repels water. Resin-impregnated hydraulic filters are available for virtually any application and are available in a ten micron nominal rating.

13

In-Line Gasoline Filters

Racor In-line Gasoline Filters keep your fuel clean and dry, because having grime and water in your fuel spells disaster. More than ever, today's high-performance gasoline engines require clean, dry fuel. Standard fuel filters simply do not hold up from normal usage, and don't offer the improved features, durability, and peace-of-mind that comes with Racor fuel filters. Experienced sailors trust their engines, their livelihood, and even their lives to Racor's high quality marine products.

14

Bilgewater Membrane Separator

Parker Racor VMT Bilgewater Membrane Separator oily water separators meet the IMO Resolution MEPC 107(49). Racor VMT units are an advanced three-stage system optimizing the separation and removal of free and emulsified oils. Heavy duty construction, corrosion resistant materials, permanent oil attractant media, quiet operation, automatic diversion valves and advanced Racor VMT membrane technology result in an easy to use, fully automated, high quality, affordable solution to meet your bilge water treatment needs.

15

Parker icountLCM20

The Parker icountLCM20 can clearly identify the condition of a fluid system, Parker Filtration has a range of fluid contamination monitoring products. Portable or installed monitors and detectors allow for the observation of fluid within the working system in most circumstances, environments and including hazardous or explosive areas requiring ATEX approved equipment.

Racor Spin On Series

Pump Diaphragm:

Racor use high quality, support laminated, high grade rubber fit-for-life diaphragms. Poor quality pump diaphragms will swell in the fuel, and leak in cold conditions, and eventually wear out under even mild pressure pulsation/vibration.

Seal Materials:

Crucial in a modern fuel filter, Racor use high quality automotive grade materials in all seals and valves. Poor quality seals will swell excessively in the fuel, and leak in cold conditions.

Filter Media:

The true heart of the filter- Racor develop proprietary semi-synthetic Aquabloc medias to meet the exacting specifications of injection system OEMs. These meet critical water removal and particle efficiency requirements. Copycats regularly save cost on low quality medias which do not perform, and block up to 70% sooner.

Accessories:

Racor have a wide range of heater and sensor accessories all validated for integrity, EMC Compatibility and safety. Unlike unauthorised copies.



Head casting:

Racor validate castings under extreme vibration and climatic conditions to meet chassis and engine specifications. Unlike unauthorised copies.

Filter Can Components:

Racor validate canisters under extreme vibration and climatic conditions to meet chassis and engine specifications. Unlike unauthorised copies.

Coatings and plating:

Racor validate canisters under extreme salt spray and climatic conditions to meet OEM specifications and environmental requirements and are free from banned substances. Unlike unauthorised copies.

Clear Bowl:

Racor use a unique and durable clear plastic bowl material with high clarity, excellent UV, Low temp/high temp resistance, impact resistant and impervious to all fuel types. Validated under extreme vibration and climatic conditions to meet strict OEM specifications. Copies often use more economical materials.

Racor Turbine Series

Seal Materials:

Crucial in a modern fuel filter, Racor use high quality automotive grade materials in all seals and valves. Poor quality seals will swell in the fuel, and leak in cold conditions.

Filter Media:

The true heart of the filter- Racor develop proprietary semi-synthetic Aquabloc media to meet the exacting specifications of injection system OEMs. These meet critical water removal and particle efficiency requirements. Copy cats regularly save cost on low quality medias which do not perform, and block up to 70% sooner.

Accessories:

Racor have a wide range of heater, electric primer Pumps, heat shields, metal bowls and sensor accessories all validated for integrity, EMC compatibility and safety. Unlike unauthorised copies.



Filter housing casting and components:

Racor validate castings under extreme vibration and climatic conditions to meet chassis and engine specifications. Unlike unauthorised copies.

Coatings and plating:

Racor validate coatings under extreme salt spray and climatic conditions to meet OEM specifications and environmental requirements and are free from banned substances. Unlike unauthorised copies.

Clear Bowl:

Racor use a unique and durable clear plastic bowl material with high clarity, excellent UV, Low temp/high temp resistance, impact resistant and impervious to all fuel types. Validated under extreme vibration and climatic conditions to meet strict OEM specifications. Copies often use more economical materials.

The Inside Story

Commercial Pure Water Series.



Water Quality Monitor – LCD readout displays fresh water quality and sea water temperature, adjustable set point, high salinity alarm, hour meter on a corrosion resistant Inconel panel



Master Control Panel – LCD readout, push button operation, low pressure protection, high salinity warning, check system indicator for diagnostics and maintenance, on a corrosion resistant Inconel panel



Aqua Pro, magnetic drive, low pressure pumps



Remote Control Panel – Push button operation, LCD ppm display, audible high salinity alarm and warning lights on a corrosion resistant Inconel panel



Aqua Pro, Titan Series, Titanium head, corrosion resistant high pressure pumps.

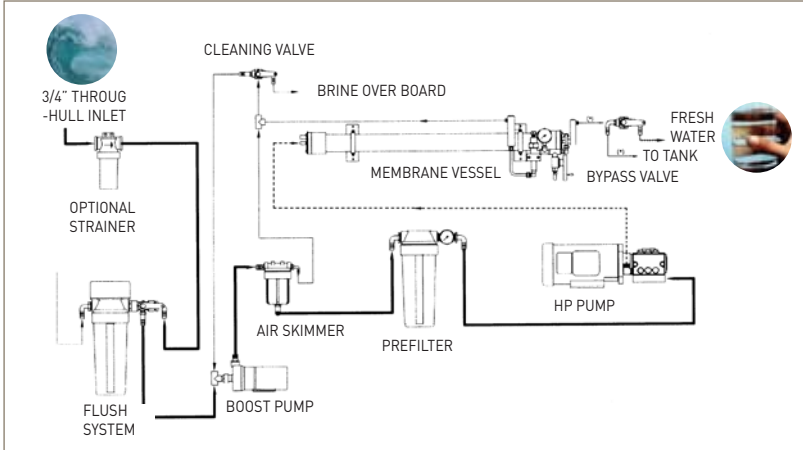

Aqua Pro, industrial grade, pleated pre-filtration



Custom made seawater membranes



Fibreglass pressure vessels



Industrial Strength reinforced high pressure hose with Titanium wetted fittings



316Stainless Steel Vibration isolation mounts



TRUE 316 Stainless Steel high pressure regulator – Eliminates risk of over pressurization



Air/Oil separator. Maintenance FREE! No Filters to Replace



Corrosion resistant, machined nylon end caps and manifolds

Parker Worldwide

AE – UAE, Dubai
Tel: +971 4 8127100
parker.me@parker.com

AR – Argentina, Buenos Aires
Tel: +54 3327 44 4129

AT – Austria, Wiener Neustadt
Tel: +43 (0)2622 23501-0
parker.austria@parker.com

AT – Eastern Europe,
Wiener Neustadt
Tel: +43 (0)2622 23501 900
parker.easteurope@parker.com

AU – Australia, Castle Hill
Tel: +61 (0)2-9634 7777

AZ – Azerbaijan, Baku
Tel: +994 50 2233 458
parker.azerbaijan@parker.com

BE/LU – Belgium, Nivelles
Tel: +32 (0)67 280 900
parker.belgium@parker.com

BR – Brazil, Cachoeirinha RS
Tel: +55 51 3470 9144

BY – Belarus, Minsk
Tel: +375 17 209 9399
parker.belarus@parker.com

CA – Canada, Milton, Ontario
Tel: +1 905 693 3000

CH – Switzerland, Etoy
Tel: +41 (0)21 821 87 00
parker.switzerland@parker.com

CL – Chile, Santiago
Tel: +56 2 623 1216

CN – China, Shanghai
Tel: +86 21 2899 5000

CZ – Czech Republic, Klecany
Tel: +420 284 083 111
parker.czechrepublic@parker.com

DE – Germany, Kaarst
Tel: +49 (0)2131 4016 0
parker.germany@parker.com

DK – Denmark, Ballerup
Tel: +45 43 56 04 00
parker.denmark@parker.com

ES – Spain, Madrid
Tel: +34 902 330 001
parker.spain@parker.com

FI – Finland, Vantaa
Tel: +358 (0)20 753 2500
parker.finland@parker.com

FR – France, Contamine s/Arve
Tel: +33 (0)4 50 25 80 25
parker.france@parker.com

GR – Greece, Athens
Tel: +30 210 933 6450
parker.greece@parker.com

HK – Hong Kong
Tel: +852 2428 8008

HU – Hungary, Budapest
Tel: +36 1 220 4155
parker.hungary@parker.com

IE – Ireland, Dublin
Tel: +353 (0)1 466 6370
parker.ireland@parker.com

IN – India, Mumbai
Tel: +91 22 6513 7081-85

IT – Italy, Corsico (MI)
Tel: +39 02 45 19 21
parker.italy@parker.com

JP – Japan, Tokyo
Tel: +81 (0)3 6408 3901

KR – South Korea, Seoul
Tel: +82 2 559 0400

KZ – Kazakhstan, Almaty
Tel: +7 7272 505 800
parker.easteurope@parker.com

MX – Mexico, Apodaca
Tel: +52 81 8156 6000

MY – Malaysia, Shah Alam
Tel: +60 3 7849 0800

NL – The Netherlands,
Oldenzaal
Tel: +31 (0)541 585 000
parker.nl@parker.com

NO – Norway, Asker
Tel: +47 66 75 34 00
parker.norway@parker.com

NZ – New Zealand, Mt Wellington
Tel: +64 9 574 1744

PL – Poland, Warsaw
Tel: +48 (0)22 573 24 00
parker.poland@parker.com

PT – Portugal, Leca da Palmeira
Tel: +351 22 999 7360
parker.portugal@parker.com

RO – Romania, Bucharest
Tel: +40 21 252 1382
parker.romania@parker.com

RU – Russia, Moscow
Tel: +7 495 645-2156
parker.russia@parker.com

SE – Sweden, Spånga
Tel: +46 (0)8 59 79 50 00
parker.sweden@parker.com

SG – Singapore
Tel: +65 6887 6300

SK – Slovakia, Banská Bystrica
Tel: +421 484 162 252
parker.slovakia@parker.com

SL – Slovenia, Novo Mesto
Tel: +386 7 337 6650
parker.slovenia@parker.com

TH – Thailand, Bangkok
Tel: +662 717 8140

TR – Turkey, Istanbul
Tel: +90 216 4997081
parker.turkey@parker.com

TW – Taiwan, Taipei
Tel: +886 2 2298 8987

UA – Ukraine, Kiev
Tel: +380 44 494 2731
parker.ukraine@parker.com

UK – United Kingdom,
Warwick
Tel: +44 (0)1926 317 878
parker.uk@parker.com

US – USA, Cleveland
Tel: +1 216 896 3000

VE – Venezuela, Caracas
Tel: +58 212 238 5422

ZA – South Africa,
Kempton Park
Tel: +27 (0)11 961 0700
parker.southafrica@parker.com

European Product Information Centre

Free phone: 00 800 27 27 5374

(from AT, BE, CH, CZ, DE, EE, ES, FI, FR, IE,
IL, IS, IT, LU, MT, NL, NO, PT, SE, SK, UK)

Parker Hannifin (UK) Ltd.
Racor Filter Division Europe
Tel: +44(0)1924 487000
Email: filtrationinfo@parker.com
www.parker.com/rfde

